



The Facet portable filtration and pumping set is an economical, light and compact packaged unit for the supply of clean, dry fuel to helicopters and light aircraft.

The standard unit is fitted with a Facet monitor housing, model VFG-21-609, differential pressure gauge and a 12 volt or 24 volt electric pump for a maximum flow of 11 gpm (42 lpm). The unit is complete with intake and delivery hoses and comes with a lightweight antidrip nozzle.

The unit can be run from a vehicle battery or from the helicopter's own power supply.

A filter monitor can be fitted as an alternative to the standard filter water separator.

Quality fuel accessories are available as options to improve and expand your transfer fuel systems for greater convenience and higher accuracies.

STANDARD PACKAGE DESIGN

- Facet monitor housing, model VFG-21-609
- Differential pressure gauge
- 22 inch (559 mm) to 40 inch (1016 mm) adjustable plastic suction pipe assembly
- 13 foot (4 metre) fuel intake hose, with nipples for coupling to the pump and fuel intake filter
- 13 foot (4 metre) discharge hose, with nipples for coupling to the pump and antidrip nozzle
- High-flow automatic nozzle
- Electric pump, flow rate 660 gph (11 gpm); 2500 lph (42 lpm)
- On/Off switch
- Electric supply cable with nippers for connection to the power supply
- Ground connection cable
- Tubular type chassis for light weight and portability
- Approximate weight: 66 lbs (30 kgs)
- Chassis Dimensions: 20 $\frac{7}{8}$ " x 23" x 14 $\frac{3}{4}$ "
(513 mm x 583 mm x 373 mm)

OPTIONS

- 12 or 24 volt D.C. pumps
- Electronic or mechanical meters
- 15 inch (381 mm) suction pipe extension assembly
- 5 gallon (19 litre) calibration container

Due to our continuing program of improvement, specifications are subject to change without notice.

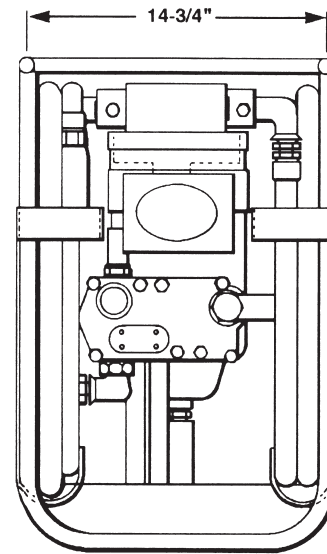
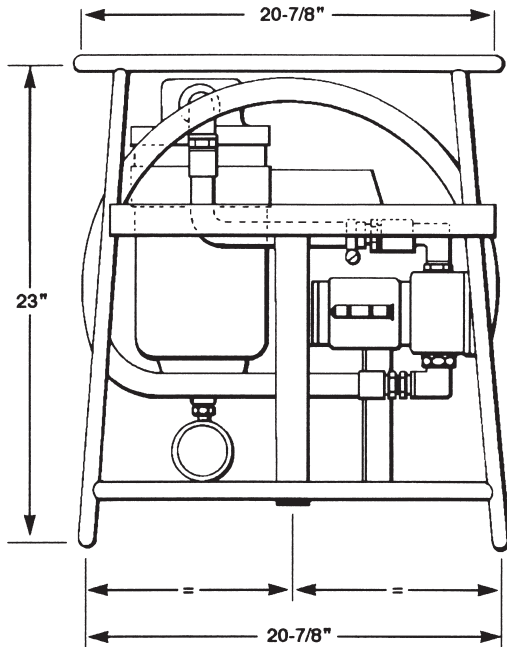

ACCESSORIES

High quality fuel accessories improve and expand your transfer fuel systems for greater convenience and higher accuracies.

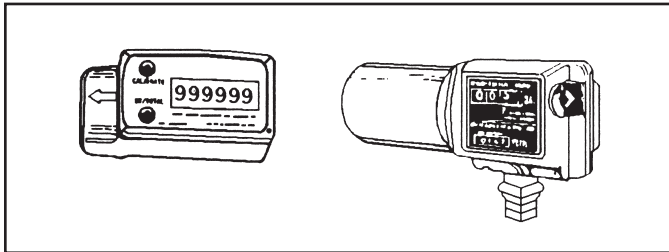

ELECTRONIC AND MECHANICAL METERS

Accurately measure fuels and fluids. A wide variety of models are available to suit all needs.

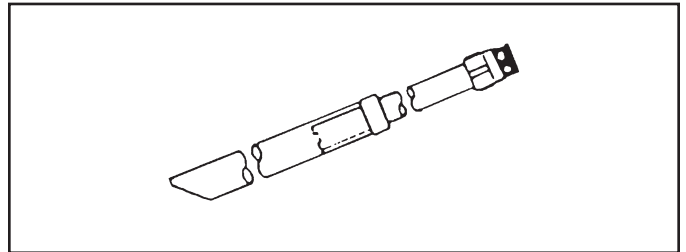

ADJUSTABLE SUCTION PIPE ASSEMBLY

Adjusts for tank sizes from 22 inch (559 mm) to 40 inch (1016 mm) depths with a 15 inch (381 mm) extension kit available for larger tanks.

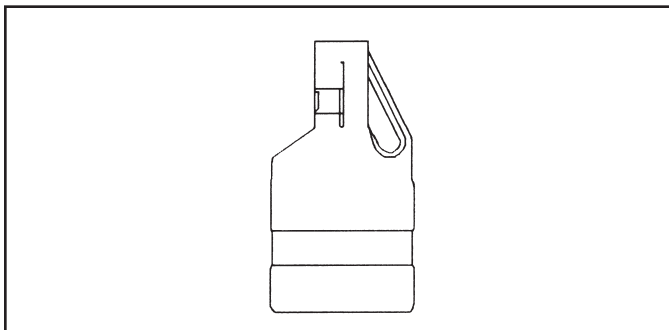

5 GALLON (19 LITRE) CALIBRATION CONTAINER

An accurate, durable, lightweight, low cost, molded container for use with any meter for calibration purposes. Individually calibrated at the factory for maximum accuracy of $\pm 0.5\%$.

(NOTE: This item is not suitable for the transportation or storage of fuel.)

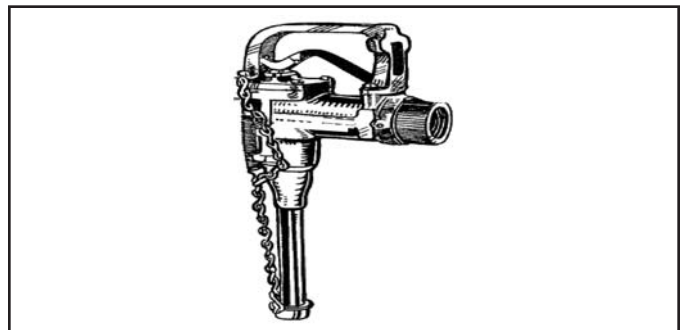

SPECIAL HIGH-FLOW AUTOMATIC NOZZLE

Specially designed to provide maximum flow rate from the pump, these nozzles are available in 1 inch (25 mm) or 1 inch (25 mm) with 3/4 inch (19 mm) reducer bushing.

Due to our continuing program of improvement, specifications are subject to change without notice.