

Facet filter housings are specifically designed to remove solid particles such as rust, dirt, pipe scale, sand and metal from fuel. They are commonly located ahead of clay treaters and coalescer separators to protect and prolong cartridge life. A single pass through the filter allows clean product to flow downstream.

Facet filter housings will continuously remove solids from fuel when used with Facet standard single, double or triple-length FA, M OR CIF Series high efficiency filter cartridges. Housings are designed for easy servicing and low maintenance. All are built to ASME Code, Section VIII, with many standard and optional accessories and connections available to facilitate individual installation requirements. Facet filters provide a complete system to meet industry standards and levels of effluent purity required by commercial airlines, major oil companies and governments, worldwide.

M Series filter housings use any of Facet's high efficiency filter cartridges. A single pass of product through the system removes solids such as rust, dirt, scale, granules and other particles commonly found in liquid process streams.

M Series filter housings are available in three styles

and in several standard sizes to accommodate specific flow and filtration requirements. They are designed with no internal moving parts to provide easy service and reduced maintenance costs. Each housing is manufactured using quality materials and workmanship to give long-lasting, dependable service.

M Series filter housings can be fitted with either multiple single-length cartridges, stacked 1, 2 or 3 high or their double-length or triple-length equivalents.

### STANDARD HOUSING DESIGN

- EI 1596 Design & Construction
- Body: Welded carbon steel construction other materials available on request
- ASME Code, Section VIII construction, stamped and certified
- Designed for 150 psi @ 250°F—higher pressure and temperature ratings available on request
- Head closures: Style A—thru-bolt  
Styles B and C—swing bolt
- Buna-N closure gasket—other materials available on request
- Rod mount cartridge hardware
- Knife edge cartridge mounting seals
- Headlift furnished on 20" (508 mm) and larger
- Inlet and outlet permanently marked
- Exterior: Prime coated
- Interior: Epoxy coated (MIL-PRF-4556)

### STANDARD CONNECTIONS

- Inlet and outlet: Style A—3000# NPT  
Style B and C—150# RF (ANSI) flanged
- Side and bottom drain: 3000# NPT
- Vent and relief valve:  $\frac{3}{4}$ " 3000# NPT
- Pressure gauge:  $\frac{1}{4}$ " 3000# NPT

### OPTIONS

- Automatic air eliminator
- Automatic air eliminator check valve
- Differential pressure gauge
- Pressure relief valve
- Manual drain valve

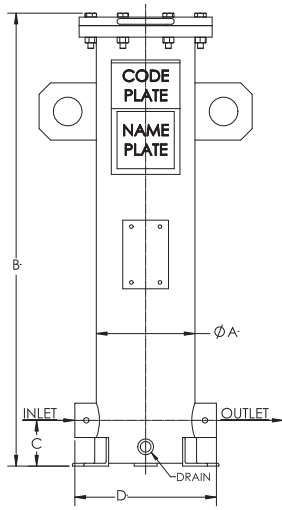

**STYLE A**

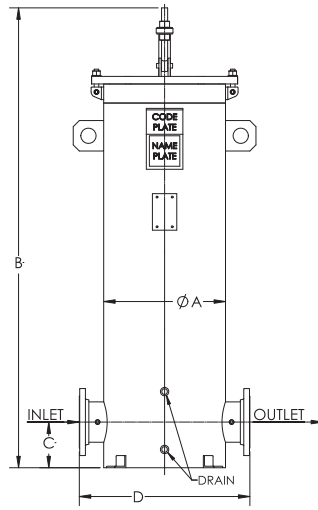

**STYLE B**

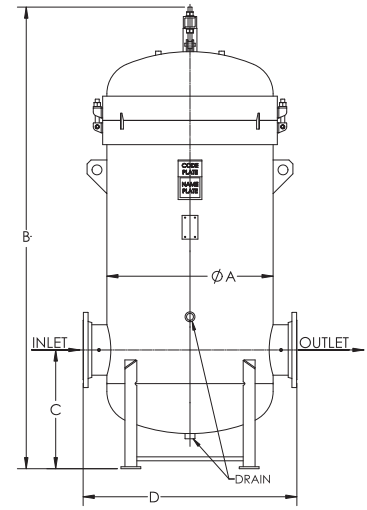

**STYLE C**

## DATA

MODEL NUMBER	MAXIMUM FLOW RATE		CONNECTIONS						ANCHOR BOLT PLAN				WEIGHT WITH CARTRIDGES		
			INLET/OUTLET		SIDE DRAIN		BOTTOM DRAIN		BOLT HOLE DIAMETER		BOLT CIRCLE				NO. OF BOLT HOLES
			gpm	lpm	in.	mm.	in.	mm.	in.	mm.	in.	mm.			
1M-114	66	250	2	51	N/A	N/A	3/4	19	7/8	22	11 1/8	295	3	110	50
1M-214	133	503	2	51	N/A	N/A	3/4	19	7/8	22	11 1/8	295	3	140	64
1M-314	200	757	2	51	N/A	N/A	3/4	19	7/8	22	11 1/8	295	3	160	73
2M-314	400	1514	4	102	3/4	19	3/4	19	7/8	22	17	432	4	450	204
3M-314	600	2271	4	102	3/4	19	3/4	19	7/8	22	19	483	4	525	238
4M-314	800	3028	6	152	3/4	19	3/4	19	7/8	22	21	533	4	650	295
6M-314	1200	4542	6	152	3/4	19	3/4	19	7/8	22	23	584	4	775	352
11M-314	2200	8328	8	203	1 1/2	38	1	25	7/8	22	24 3/8	625	4	1225	556
18M-314	3600	13627	10	254	1 1/2	38	1	25	7/8	22	31 3/8	797	4	1950	885
27M-314	5400	20441	12	305	1 1/2	38	1 1/2	38	1	25	39 3/8	1000	4	2700	1225

Other sizes available on request.

## DIMENSIONS

MODEL NUMBER	DIMENSIONS								HOUSING LIQUID VOLUME		HOUSING TYPE
	A		B		C		D		gals.	ltrs.	
	in.	mm.	in.	mm.	in.	mm.	in.	mm.			
1M-114	8 3/8	219	24 1/4	616	4	102	12 3/8	314	5	19	Style A - Flat
1M-214	8 3/8	219	39 1/2	1003	4	102	12 3/8	314	9	34	Style A - Flat
1M-314	8 3/8	219	54 1/2	1378	4	102	12 3/8	314	12	45	Style A - Flat
2M-314	14	355	72 3/4	1848	6	152	22	559	36	136	Style B - Flat
3M-314	16	406	72 3/4	1848	6	152	24	610	48	182	Style B - Flat
4M-314	18	457	75 1/4	1911	7 1/2	191	26	660	63	238	Style B - Flat
6M-314	20	508	75 1/2	1918	7 1/2	191	28	711	78	295	Style B - Flat
11M-314	28	711	103 1/4	2623	24	610	36	914	205	776	Style C - Dished
18M-314	34	864	109 1/2	2781	27	686	46	1168	315	1192	Style C - Dished
27M-314	42	1067	116 3/4	2965	30	762	54	1371	520	1968	Style C - Dished

All dimensions, weights and volumes are approximate and are for estimating purposes only.

### NOTES:

- Cartridges are selected separately to fit specific application requirements.
- Multiple stack cartridges can be replaced with one single-length equivalent. For example: 1M-214 = 1M-128 or 6M-314 = 6M-143, etc.
- Consult factory for flow rates when using EI 1590 Qualified Elements.