

STANDARD HOUSING DESIGN

- Body: Carbon steel
- Aluminum Head
- Interior and exterior: Epoxy coated
- Design pressure: 150 psi
- Closure: Swing-bolt
- Closure seal: Buna-N o-ring—other materials available upon request
- Vent and drain connections with brass petcocks provided
- Inlet and outlet connections: 1 ½" NPT female threaded
- One filter cartridge installed

VESSEL OPTIONS

VF-21SB	Housing only
VF-21SB-PG	Housing w/Direct Reading Differential Pressure Gauge
VF-22SB	Housing Only
VF-22SB-PG	Housing w/ Direct Reading Differential Pressure Gauge
644160	Mounting Bracket

The Facet VF-21SB/22SB can be used as a filter housing. They are versatile, compact, light weight housings and provide superior in-line filtration protection.

Both interior and exterior surfaces of the carbon steel body are epoxy coated to protect against corrosion. This sturdy, single cartridge housing is easy to maintain and requires only 2" (51 mm) base clearance for cartridge change out.

Differential Pressure Gauge- The piston-type differential pressure gauge provides a simple visual warning. When 15 psi differential pressure is reached, the gauge indicator moves from green to red zone. This warning will prevent premature cartridge change-out.

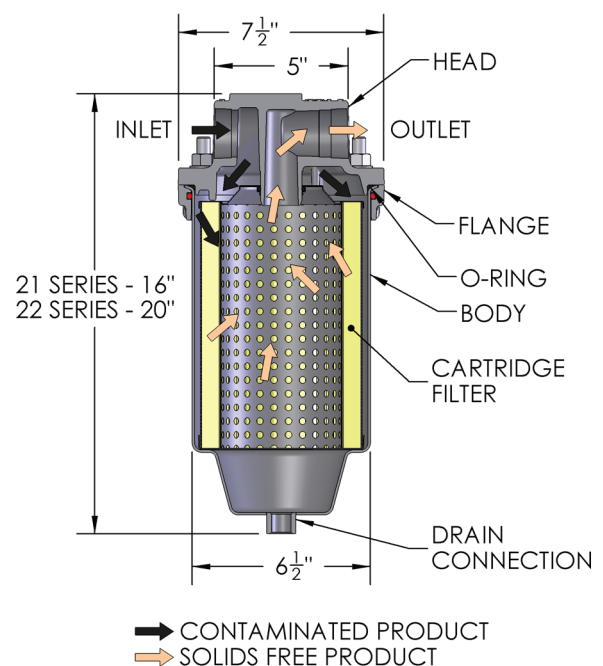

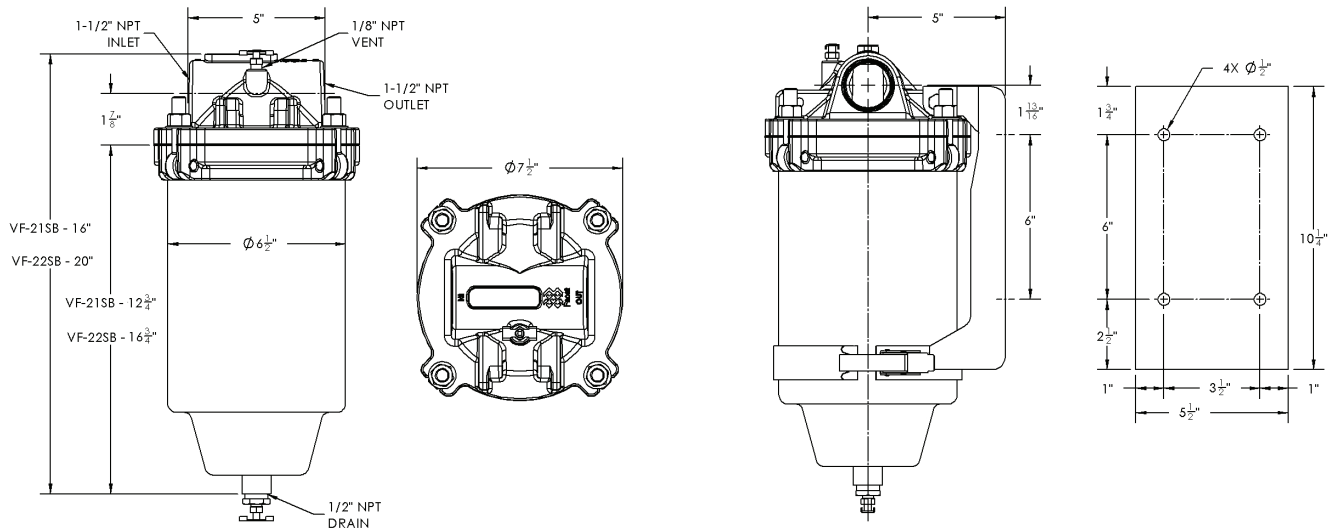

VF-21SB/22SB Filter Cartridges



Facet VF-21SB/22SB Series filter cartridges provide long service life and high solids holding capacity with no unloading characteristics. The filter cartridges remove solids from aviation fuels.

STANDARD DESIGN FEATURES

- 2 and 5 Micron Cartridges—other Micron ratings available upon request
- Recommended maximum operating temperature: 240°F
- Maximum differential pressure: 75 psi
- pH range from 5 to 9
- Flow direction: Outside to in

MATERIALS

- Carbon steel structural components
- All metal components coated to protect against corrosion
- Standard gaskets are Buna-N—other materials available on request

DATA

MODEL NUMBER	OUTSIDE DIAMETER		NOMINAL LENGTH		SHIPPING WEIGHT	
	in.	mm.	in.	mm.	lbs.	kgs.
21 SERIES						
CF-609-2PLO	6	152	9	230	4	1.8
CF-609-5PLO	6	152	9	230	4	1.8
22 SERIES						
CF-612-2PLO	6	152	12	300	6	2.7
CF-612-5PLO	6	152	12	300	6	2.7

FLOW RATES

MODEL NUMBER	JET FUEL				AV-GAS			
	INITIAL ΔP		FLOW		INITIAL ΔP		FLOW	
	psi	kPa	gpm	lpm	psi	kPa	gpm	lpm
21 SERIES								
CF-609-2PLO	2.1	14.5	45	170	1.2	8.3	45	170
CF-609-5PLO	2.1	14.5	45	170	1.2	8.3	45	170
22 SERIES								
CF-612-2PLO	3.1	21.4	60	227	1.6	11.0	60	227
CF-612-5PLO	3.1	21.4	60	227	1.6	11.0	60	227