

Facet's standard carbon steel MS Series SuperFlex filter housings are small, economical housings for in-line removal of solids from aviation fuels when equipped with Facet's M Series filter cartridges, stacked 1, 2 or 3 high. Stainless steel construction is available. Contact your Facet representative for details.

STANDARD HOUSING DESIGN

- Welded carbon steel construction
- ASME Code, Section VIII construction, stamped and certified
- Design pressure: 250 psi @ 250°F
- Main closure: Blind flange
- Head gasket: Buna-N—other materials available on request
- Vent connection: 3/4" NPT
- Drain connection: 3/4" 3000# NPT
- Inlet and outlet connections: 2" 3000# NPT
- Differential pressure gauge connection: 1/8" NPT
- Interior: Epoxy coated
- Exterior: Prime coated

OPTIONS

- Air eliminator
- Air eliminator check valve
- Manual drain valve
- Pressure gauge assembly
- Pressure relief valve
- Sampling probe
- Adjustable support stand

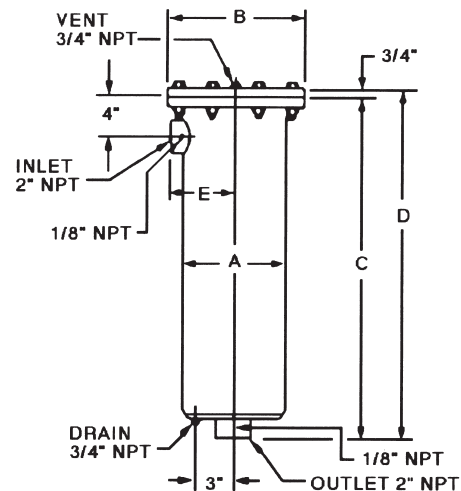

HOUSING DATA

MODEL NUMBER	JET FUEL and AV-GAS*		A		B		C		D		E		WEIGHT		LIQUID VOLUME	
	gpm	lpm	in.	mm.	in.	mm.	in.	mm.	in.	mm.	in.	mm.	lbs.	kgs.	gals.	ltrs.
MS-1C-A	66	250	8 ⁵ / ₈	219	11 ⁵ / ₈	295	31	787	31 ³ / ₄	806	5 ¹ / ₂	140	110	50	7	26
MS-2C-A	133	503	8 ⁵ / ₈	219	11 ⁵ / ₈	295	45 ¹ / ₂	1155	46 ¹ / ₄	1175	5 ¹ / ₂	140	125	57	10	38
MS-3C-A	200	757	8 ⁵ / ₈	219	11 ⁵ / ₈	295	59 ¹ / ₂	1511	60 ¹ / ₄	1530	5 ¹ / ₂	140	151	68	13	49

Initial Pressure Drop 2 psig

Cartridges are selected separately to fit specific application requirements and will be included in the final housing model number.

All dimensions, weights and volumes are for estimating only.

*Consult factory for flow rates when using API/IP-1590 Qualified Elements.

Due to our continuing program of improvement, specifications are subject to change without notice.