

The Facet HFG Series Horizontal Fuel-Gard® monitor housings, equipped with Facet's FG Series monitor cartridges, continually check the entire flow of fuel, not just mere samples, for water or solids contamination. By performing three jobs, the FG Series monitors assure clean, dry fuel. They absorb free and emulsified water, remove ultra-fine solids, and shut down system flow when hit with a localized slug of water. They are designed to flow from the outside to inside at a rate of 1 gallon (3.79 liters) per inch of length.

Facet's Fuel-Gard® monitor housings are built to ASME Code, constructed of carbon steel and designated for maximum working pressure of 150 psi. They are furnished with FG Series monitor cartridges that meet and exceed the latest edition of EI Specification 1583 Aviation Fuel Filter Monitors with Absorbent Type Elements.

STANDARD HOUSING DESIGN

- EI 1596 Design & Construction
- Welded carbon steel construction—other materials available on request
- ASME Code, Section VIII construction, stamped and certified
- Maximum working pressure: 150 psi
- Swing bolt closures on 8⁵/₈" (219 mm.) OD housings and larger
- Buna-N closure o-ring—other materials available
- Exterior: Prime coated
- Interior: Epoxy coated (MIL-PRF-4556)
- Spider plate

STANDARD CONNECTIONS

- Flanged inlet and outlet connections
- Drain connection: ¾" NPT
- Vent and relief valve connections: ¾" NPT
- Differential pressure gauge connections: ¼" NPT

OPTIONS

- Automatic air eliminator
- Automatic air eliminator check valve
- Pressure relief valve
- Differential pressure gauge
- Sampling probes
- Manual drain valve
- Victaulic inlet and outlet connections
- Interlock Device

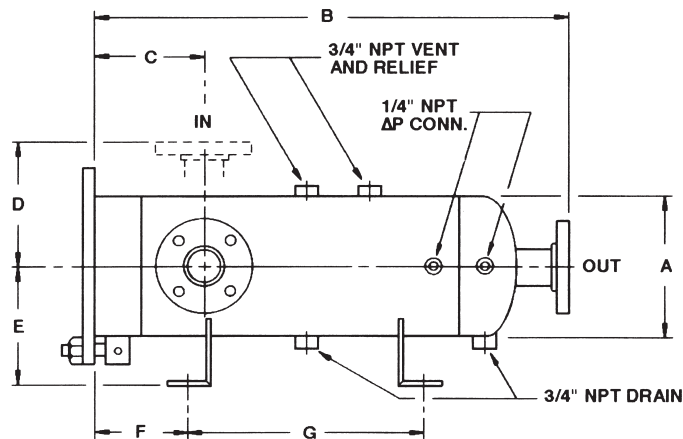

DATA

MODEL NUMBER	FLOW RATE		REQUIRED CARTRIDGES ⁽¹⁾		LIQUID VOLUME		DRY WEIGHT		HOUSING TYPE
	gals.	ltrs.	qty.	model	qty.	ltrs.	lbs.	kgs.	
HFG-C-5210	50	189	5	FG-210-6	3	11	235	107	FLAT
HFG-C-5220	100	379	5	FG-220-6	4	15	250	113	FLAT
HFG-C-5230	150	568	5	FG-230-6	5.5	21	265	120	FLAT
HFG-C-10220	200	757	10	FG-220-6	7.5	28	310	141	FLAT
HGF-C-10230	300	1136	10	FG-230-6	10	38	350	159	FLAT
HFG-C-20230	600	2271	20	FG-230-6	20	76	385	175	FLAT
HFG-C-30230	900	3406	30	FG-230-6	30	114	450	204	FLAT
HFG-C-40230	1200	4542	40	FG-230-6	40	151	490	222	FLAT

DIMENSIONS

MODEL NUMBER	INLET/OUTLET DIAMETER		A		B		C		D		E		F		G	
	in.	mm.	in.	mm.	in.	mm.	in.	mm.	in.	mm.	in.	mm.	in.	mm.	in.	mm.
HFG-C-5210	2	51	6 ⁵ / ₈	168	28	711	7	178	7	178	6 ¹ / ₄	159	6	152	13	330
HFG-C-5220	2	51	6 ⁵ / ₈	168	38	965	7	178	7	178	6 ¹ / ₄	159	6	152	23	584
HFG-C-5230	2	51	6 ⁵ / ₈	168	48	1219	7	178	7	178	6 ¹ / ₄	159	6	152	33	838
HFG-C-10220	3	76	8 ⁵ / ₈	219	40	1016	8	203	8	203	7 ¹ / ₄	184	6	152	24	610
HGF-C-10230	4	102	8 ⁵ / ₈	219	52	1321	9	229	8	203	7 ¹ / ₄	184	6	152	36	914
HFG-C-20230	6	152	12 ³ / ₄	324	55	1397	10	254	10	254	9 ¹ / ₂	241	6	152	38	965
HFG-C-30230	6	152	14	356	55	1397	10	254	11	279	10	254	6	152	38	965
HFG-C-40230	6	152	16	406	56	1422	10	254	12	305	11	279	6	152	38	965

All dimensions, weights and volumes are approximate and are for estimating purposes only.

Caution: Monitor cartridges should never be used with fuels containing anti-icing additive (FSII, PRIST, DI-EGME). This includes pre-mixed and Military fuels containing this additive.