

J Series (J-10 to J-50)



OPERATION DESCRIPTION

Hot engine cooling water is pumped by the engine circulating pump through the seawater heater and back to the engine circulating system. This water is not affected in any way except that some heat is removed. This is the heat that boils the seawater in the distilling shell. As this takes place under deep vacuum, the seawater is boiled at a very low temperature (46-60°).

Raw seawater is pumped continuously through the fresh water condenser. Most of the seawater is then discharged to sea. A certain quantity, however, is fed into the distilling shell where it is boiled, the seawater concentrate, or brine, is continuously drawn off from the distilling shell by a venturi ejector and discharged to sea.

The vapor or steam, produced by boiling the seawater, passes through a monel mesh separator where any droplets of water or entrained particles are removed. Thus, only pure vapor enters the fresh water condenser section. This vapor passes over the tubes of the fresh water condenser where it is condensed by the cool seawater flowing through the tubes. The resultant fresh water is pumped from there to the storage tank by the fresh water pump.

The distilling shell vacuum is maintained by evacuating the non-condensable gases from the shell with a venturi ejector.

All fresh water is monitored by the salinity control system with automatic dumping should the water contain more than 4 ppm. of salt.

Safe design against failure protects valuable freshwater storage from possible salt contamination.

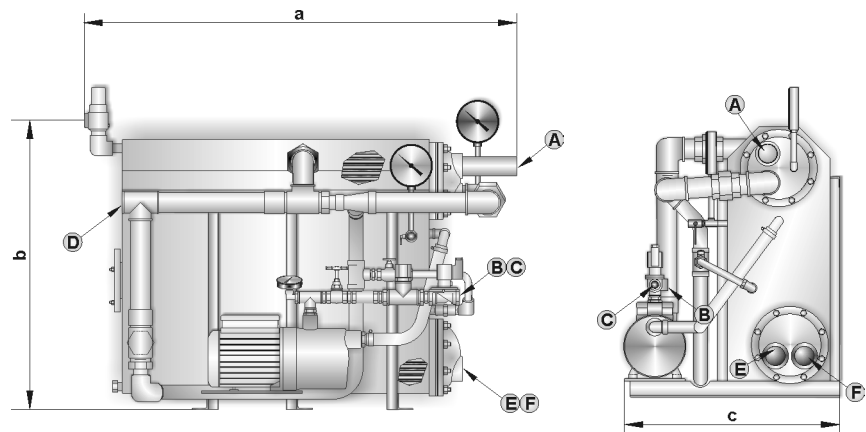
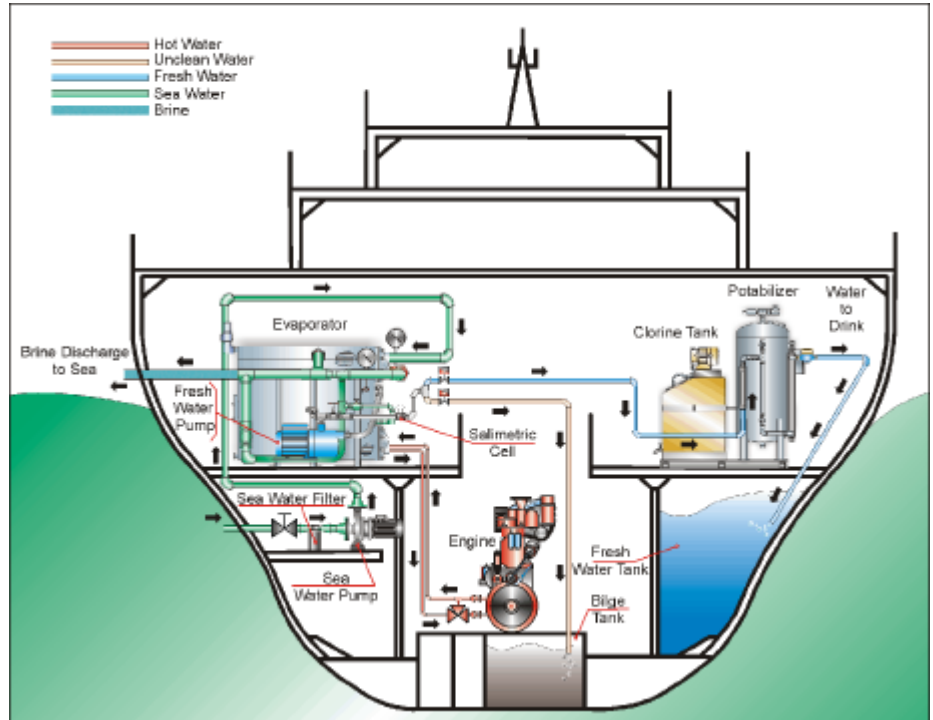

- (1) Flanged connections available on request
- (2) Other power supply are available on request
- (3) Other capacities available on request

	MODEL				
FEATURES	J-10	J-20	J-25	J-30	J-50
Capacity (m3/day)	1.5-2	3.5 - 4	4 - 5	5 - 6	9 - 10
Hot water flow rate (m3/h - 85 °C)	4.5	9	11.3	13.5	22.7
Minimum requirements to produce (KCal/h)	47115	94485	118125	142000	235600
Power consumption (Kw)	2.4	2.6	3.0	3.0	3.5
Net weight	145	236	280	290	440
Operative weight	190	285	335	345	510
Power supply	380-220V 3 phase 50 cycles, 440-110V 3 phase 60 cycles				
DIMENSIONS (mm)					
a (length)	860	1043	1087	1138	1200
b (height)	555	704	809	809	1005
c (width)	485	534	600	600	665
CONNECTIONS					
A (sea water inlet)	1" RM	1-1/2" RM	1-1/2" RM	2" RM	2" BSP, RH
B (fresh water discharge)	1/4" RH	1/2" RH	1/2" RH	1/2" RH	3/4"
C (bilge discharge)	1/2" RH	1/2" RH	1/2" RH	3/4"	3/4"
D (brine discharge)	1-1/2" RH	1-1/2" RH	1-1/2" RH	1-1/2" RH	2-1/2" BSP
E (hot water inlet)	1" RH	1-1/2" RH	2" RM	2" RM	2" BSP
F (hot water return)	1" RH	1-1/2" RH	2" RM	2" RM	2" BSP