

J Series (J-60 to J-150)

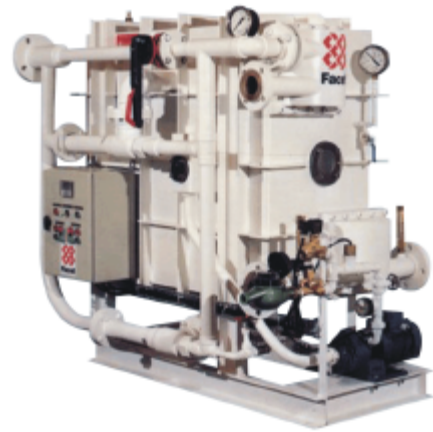

OPERATION DESCRIPTION

Hot engine cooling water is pumped by the engine circulating pump through the seawater heater and back to the engine circulating system. This water is not affected in any way except that some heat is removed. This is the heat that boils the seawater in the distilling shell. As this takes place under deep vacuum, the seawater is boiled at a very low temperature (46-60°).

Raw seawater is pumped continuously through the fresh water condenser. Most of the seawater is then discharged to sea. A certain quantity, however, is fed into the distilling shell where it is boiled, the seawater concentrate, or brine, is continuously drawn off from the distilling shell by a venturi ejector and discharged to sea.

The vapor or steam, produced by boiling the seawater, passes through a monel mesh separator where any droplets of water or entrained particles are removed. Thus, only pure vapor enters the fresh water condenser section. This vapor passes over the tubes of the fresh water condenser where it is condensed by the cool seawater flowing through the tubes. The resultant fresh water is pumped from there to the storage tank by the fresh water pump.

The distilling shell vacuum is maintained by evacuating the non-condensable gases from the shell with a venturi ejector.

All fresh water is monitored by the salinity control system with automatic dumping should the water contain more than 4 ppm. of salt.

Safe design against failure protects valuable freshwater storage from possible salt contamination.

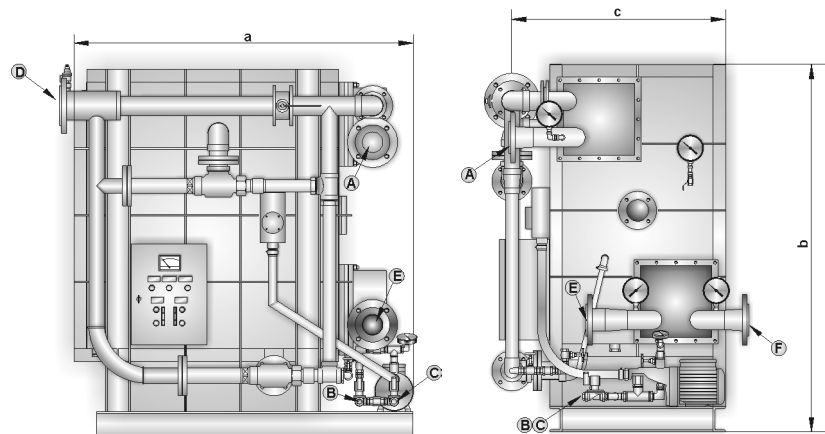
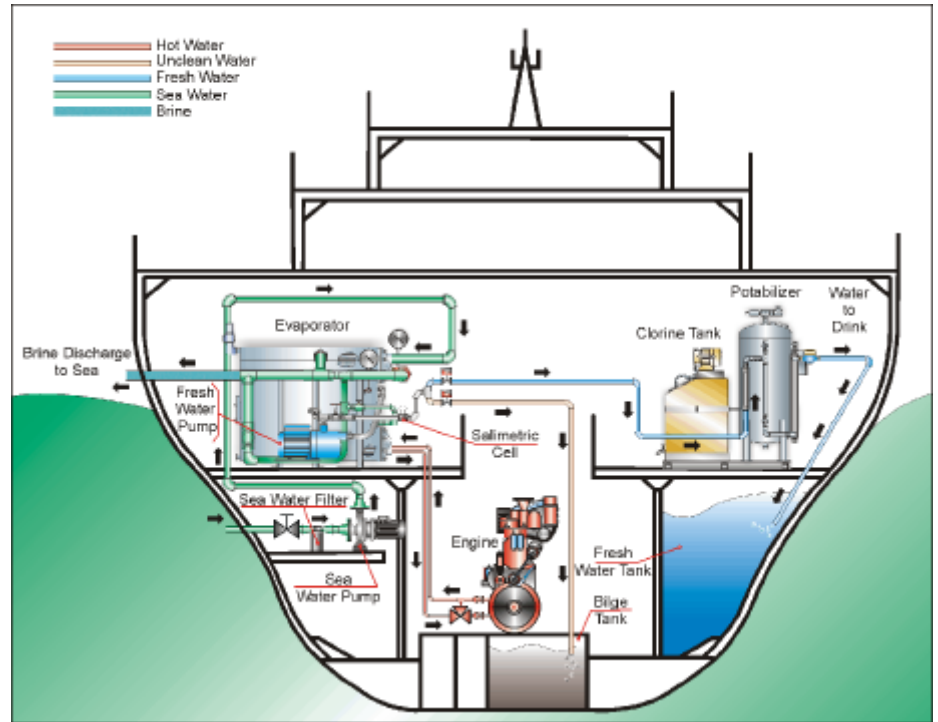

- (1) Feed with steam available on request
- (2) Other power supply are available as required
- (3) Other capacities available on request

	MODEL			
	J-60	J-70	J-100	J-150
FEATURES				
Capacity (m3/day)	10-16	12-19	15-22	20-30
Hot water flow rate (m3/h - 85 °C)	27	32	66	87
Minimum requirements to produce (KCal/h)	270000	325000	475000	540000
Power consumption (Kw)	6.7	6.7	10.4	10.4
Net weight	840	900	970	1050
Operative weight	1090	1170	1270	1380
Power supply	380-220V 3 phase 50 cycles, 440-110V 3 phase 60 cycles			
DIMENSIONS (mm)				
a (length)	1350	1350	1350	1650
b (height)	1296	1480	1460	1550
c (width)	728	1050	850	950
CONNECTIONS				
A (sea water inlet)	DN 50, PN6 DIN 2641 FF	2 1/2"	DN 80, PN 10	DN 65 DIN 2641 FF
B (fresh water discharge)	3/4"	3/4"	3/4" RH	3/4"
C (bilge discharge)	3/4"	3/4"	3/4" RH	3/4"
D (brine discharge)	DN 80, PN 6 DIN 2641	3"	DN 100, PN 10	DN 100, DIN 2641
E (hot water inlet)	DN 65, PN 6 DIN 2641 FF	2 1/2"	DN 80, PN 10	DN 80, PN 6 DIN 2641 FF
F (hot water return)	DN 65, PN 6 DIN 2641 FF	2 1/2"	DN 80, PN 10	DN 80, PN 6 DIN 2641 FF