



Series BS

BS Series filter housings use a Facet's stainless steel high efficiency basket strainer. A single pass of product through the system removes solids such as rust, dirt, scale, granules and other particles commonly found in liquid process streams.

BS Series filter housings are available in several standard sizes to accommodate specific flow and filtration requirements. They are designed with no internal moving parts to provide easy service and reduced maintenance costs. Each housing is manufactured using quality materials and workmanship to give long-lasting, dependable service.

BS Series filter housings are fitted with a cleanable basket made of st. steel perforated plate with st. steel mesh.

STANDARD DESIGN FEATURES

- Body: Welded carbon steel construction, other materials available on request
- ASME Code, Section VIII construction, stamped and certified or "CE" marked
- Designed for 150 psi (10.5 kg/cm²) at 250°F (121°C); higher pressure and temperature ratings available on request
- Head closures: swing bolt closure
- Head gasket: Buna-N O-ring, other materials available on request
- Inlet and outlet permanently marked
- Exterior: Primer coated
- Interior: Epoxy coated

- Headlift furnished on 20" (508 mm) and larger

STANDARD CONNECTIONS

- Inlet and outlet: 150# RF (ANSI) flanged
- Side and bottom drain: 3000# NPT
- Vent and relief valve: 3/4" 3000# NPT
- Pressure gauge: 3/4" 3000# NPT

OPTIONS

- Air eliminator
- Differential pressure gauge
- Pressure relief valve
- Manual drain valve
- Stainless steel wedge wire basket
- Thru bolts closure

STANDARD CONNECTIONS

- Inlet and outlet: 150# RF (ANSI) flanged
- Side and bottom drain: 3000# NPT
- Vent and relief valve: 3/4" 3000# NPT
- Pressure gauge: 3/4" 3000# NPT

OPTIONS

- Air eliminator
- Differential pressure gauge
- Pressure relief valve
- Manual drain valve
- Stainless steel wedge wire basket
- Thru bolts closure

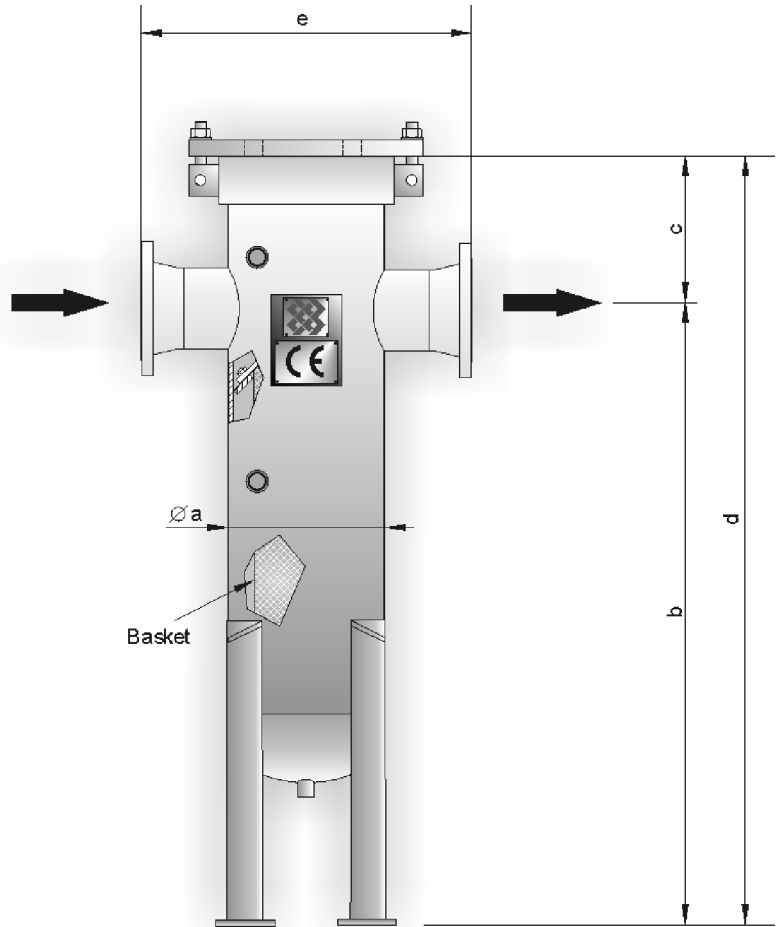

MODEL	DIMENSIONS (mm)				
	øa	b	c	d	e
BS-2	140	300	140	440	250
BS-3	168	415	175	590	425
BS-4	219	680	240	920	510
BS-6	273	1050	270	1320	580
BS-8	324	1140	330	1470	686
BS-10	356	1300	350	1650	420
BS-12	458	1250	390	1640	846
BS-14	458	1320	400	2020	872
BS-16	508	1815	500	2315	922
BS-20	610	1900	600	2500	1060
BS-24	711	2800	800	3600	1220